

The information contained herein is for reference only and does not imply a performance guarantee or a product warranty.

## Cell Characteristics

<b>Capacity</b> (C/5)	Typical: 3800 mAh Minimum: 3750 mAh
<b>Voltage</b>	Nominal: 3.55 V Charge: 4.2 V Discharge: 2.5 V
<b>Charge Current</b>	Standard: 1.9 A
<b>Discharge Current</b>	Standard: 3.8 A Maximum: 10 A
<b>Temperature</b>	Discharge: -30°C to 60°C Charge: 0°C to 60°C Storage: -40°C to 60°C
<b>Energy Density</b> (C/5)	Minimum: 777 Wh/L
<b>Specific Energy</b> (C/5)	Minimum: 270 Wh/kg
<b>Impedance</b> (AC 1kHz)	Maximum: 30 mΩ Typical: 24 mΩ
<b>Recovered Capacity</b> (60°C, 100% SoC)	56d: ≥95% 84d: ≥90%

## Physical Characteristics

<b>Shape</b>	Cylindrical
<b>Weight</b>	Maximum: 50 g

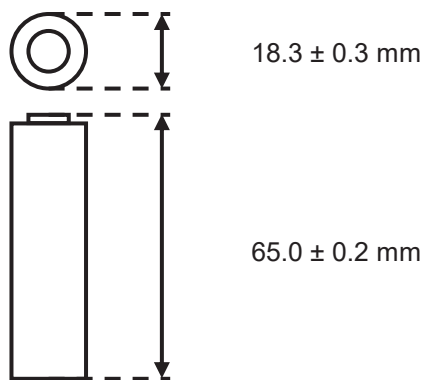
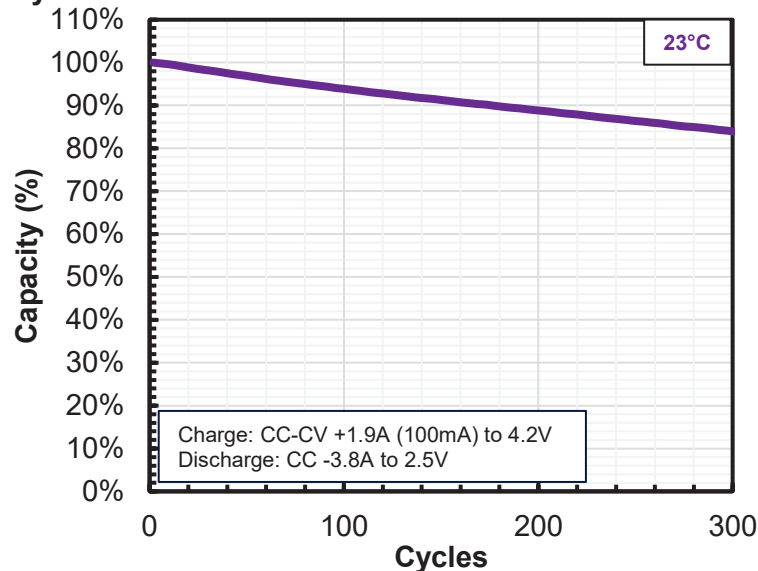
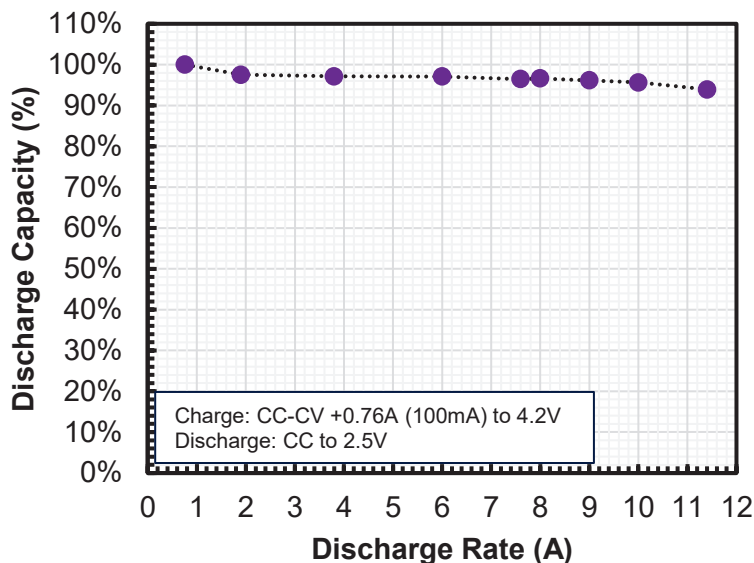

Figure NOT drawn to scale

## Cycle Characteristics



## Discharge Rate Characteristics at 23°C



## Discharge Temperature Characteristics

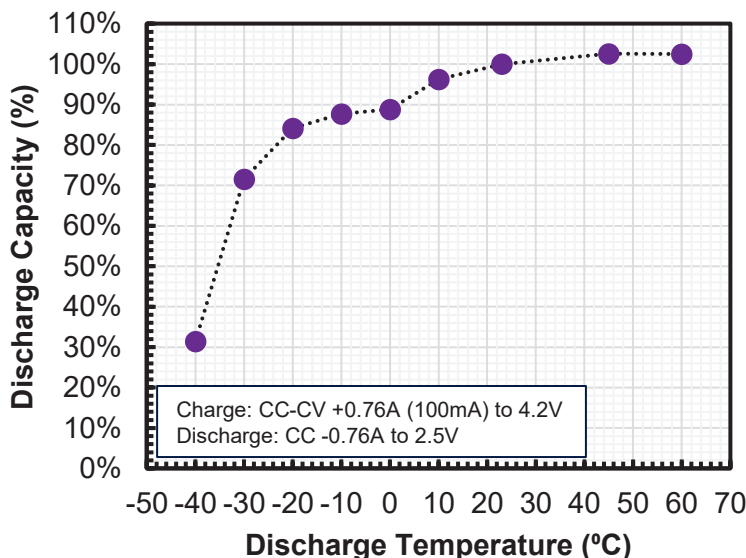

The information contained herein is for reference only and does not imply a performance guarantee or a product warranty.

## Cell Characteristics

<b>Capacity (C/5)</b>	Typical: 3800 mAh Minimum: 3750 mAh
<b>Voltage</b>	Nominal: 3.55 V Charge: 4.2 V Discharge: 2.5 V
<b>Charge Current</b>	Standard: 1.9 A
<b>Discharge Current</b>	Standard: 3.8 A Maximum: 10 A
<b>Temperature</b>	Discharge: -30°C to 60°C Charge: 0°C to 60°C Storage: -40°C to 60°C
<b>Energy Density (C/5)</b>	Minimum: 777 Wh/L
<b>Specific Energy (C/5)</b>	Minimum: 270 Wh/kg
<b>Impedance (AC 1kHz)</b>	Maximum: 30 mΩ Typical: 24 mΩ
<b>Recovered Capacity (60°C, 100% SoC)</b>	56d: ≥95% 84d: ≥90%

## Physical Characteristics

<b>Shape</b>	Cylindrical
<b>Weight</b>	Maximum: 50 g

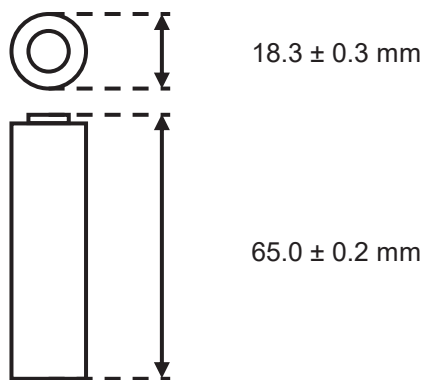
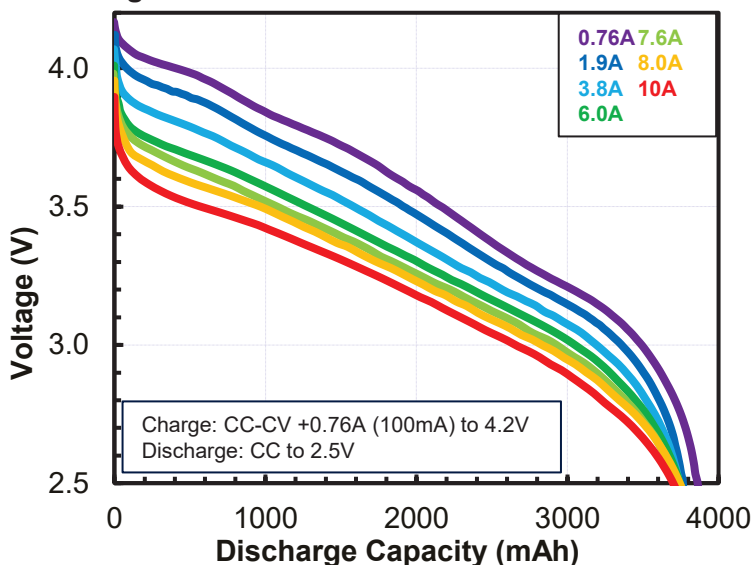
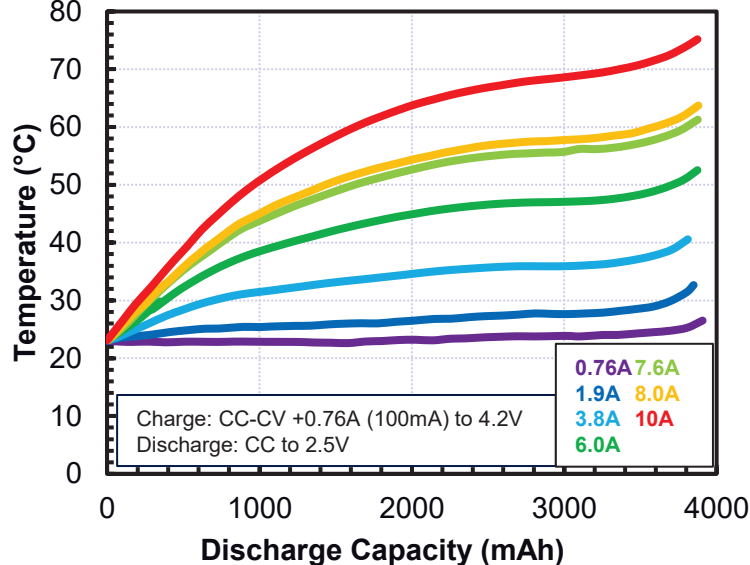

Figure NOT drawn to scale

## Discharge Rate Characteristics at 23°C



## Discharge Rate Characteristics (Skin Temp.) at 23°C



## Discharge Temperature Characteristics

